



DO NOT CONNECT to 24VDC 
You need a control current drive

PREAMBLE

This Technical User Guide contains warnings and guidance for correct and safe operation of the product. These instructions must be followed at all times. TPL Vision will not be held responsible for problems caused by using the product contrary to these instructions and the Warranty will be deemed invalid.



UNPACKING

This product is packed at the factory using suitable materials for safe transport. To open the package, do not use any cutting blade to avoid damaging the product(s). Please use the delivered accessories if needed. (Do not use any other products or equivalents to replace the delivered accessories). In the event of damage occurring during shipping, it must be reported to the carrier at time of delivery (including noting the damage in writing on the delivery documents). It is also your responsibility to notify TPL Vision in writing of the damage within 24 hours of receipt of the package. If these instructions are not followed, TPL Vision reserves the right not to accept requests for return and exchange of damaged products.

RISK CLASS

The applicable Standard EN-62471 classifies LED Lighting into 4 classes according to their degree of hazard severity. The table below summarises the risks associated with our standard products.

Colour	Class	Risk
Green 525 nm, Red 630 nm, IR 850 nm	0	none
White WHI, Blue 470 nm	1	low

TPL Vision can provide **guidance notes to minimise photo-biological risks**, including the nominal minimum operating distance. Please contact TPL Vision through your **usual representative** for this information.

In all cases, TPL Vision recommends the use of **the protection glasses** that are listed in its catalog.

NOTE Optical Safety Risk Assessments have been carried out assuming safe operation of the device within the defined thermal limits described in this document. As this is an unrestricted device, any operation beyond the limits defined in this document are at the users risk.



MODULAR M-TBAR EXTERNAL CONTROL

TECHNICAL USER GUIDE

P2/8

■ DIMENSIONS

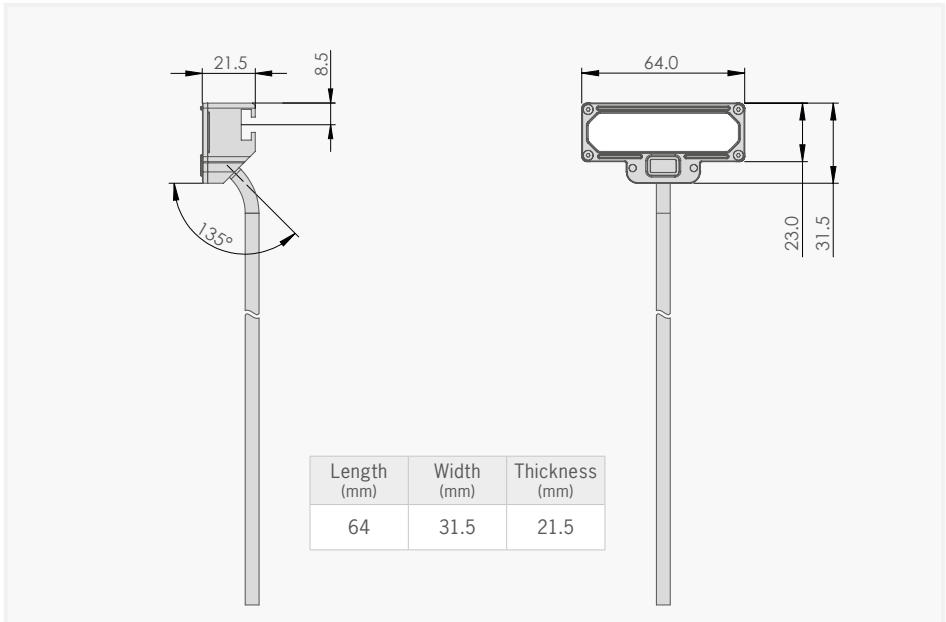

■ M-TBAR FIXING

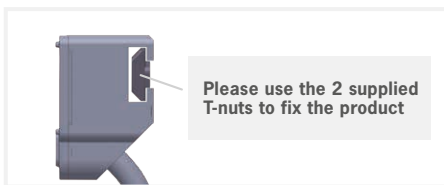

During the set up, the light has to be switched off and unplugged. Please use M4 screws and use the slot on the back of the light. Alternatively, you can use the M2 threads. Mount the power supply box using the integrated M4 threads.

■ ANGLE CHANGER FIXING



Use the 2 screws supplied to secure Angle Changer in place (recommended for final light installation).



DO NOT CONNECT to 24VDC 
You need a control current drive

CONNECTION

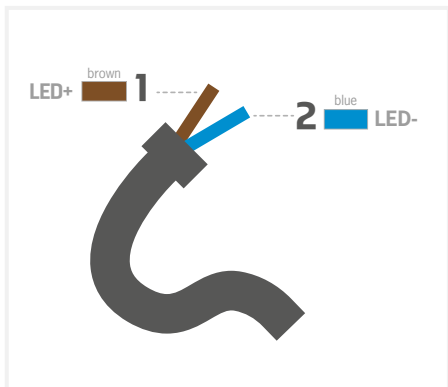

LED CONNECTION

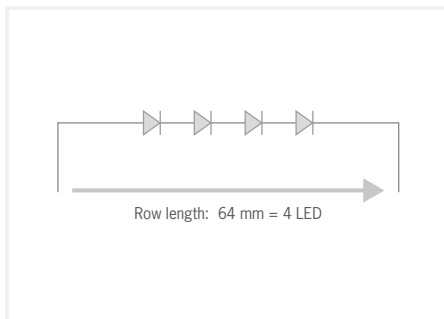

The LED are connected in series (branch of 4 LED).
All 4 LED are then connected in parallel.

LED FEATURES

Voltage at the LED terminals according to current and colours :

	Red	Infrared	Blue & White	Green
Current «I» /LED	Voltage «Vf» (±20%)/LED	Voltage «Vf» (±20%)/LED	Voltage «Vf» (±20%)/LED	Voltage «Vf» (±20%)/LED
CW up to 300 mA	2.1	2.85	2.9	2.8
Limit: 2000 mA	3.5	3.7	4.1	3.8

Current «I» /LED	Duty cycle «D» max (%)	Pulse time «t» max
Up to 300 mA	100	infinite
500 mA	50	100 ms
700 mA	25	50 ms
1050 mA	11	10 ms
1500 mA	5	1 ms
2000 mA	1	0.5 ms

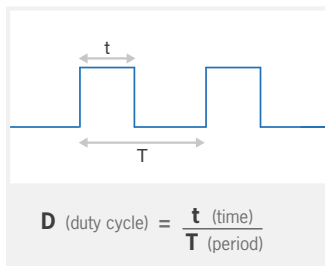

Min current: 100mA. **LED rising time:** 400 nanoseconds (0.4µs).
Voltage to keep at the product input (entry of the cable): $V_f \times 4 + 2.5VDC$.



MODULAR M-TBAR EXTERNAL CONTROL TECHNICAL USER GUIDE

DO NOT CONNECT to 24VDC ⚠
You need a control current drive

■ USER SAFETY

Do not modify or dismantle all or part of the product.
Respect the power supply voltages and the connection terminals. ⚠
Ensure power supply is switched off whilst connecting product and turn on only once product is fully connected. Failure to do this may damage the product and invalidate the Warranty
Do not stare at the lighting source directly.
Follow advice below for installation to minimise operator exposure to the light source.

INSTALLATION GUIDANCE:

- Forbid or limit the direct access to the lighting source (exposure into the radiation axis).
- Establish a security perimeter to prevent the operators from approaching the lighting source beyond the recommendations of the manufacturer.
- If the workstation permits it, introduce a filter that will stop the lighting radiation under a fixed or adjustable frame between the source and the operator. When these measures cannot be implemented, supply the operators with glasses (class 4) available from TPL Vision.

It is the responsibility of the persons installing this product to ensure that all means possible (such as those stated above) have been implemented to reduce exposure of the machine operators to the light emitted from this product.



High ambient temperatures and insufficient heat dissipation can lead to hot housing surfaces. Do not touch the light during operation. Keep a minimum distance of 20 mm between the light and thermally insulating surfaces or mount the light on a thermally conductive surface.

WARRANTY: for products supplied without an embedded current control drive, the 3-year warranty covers manufacturing defects only. Damage resulting from operation outside the product datasheet specifications (incl. overcurrent, incorrect voltage, or reverse polarity) is excluded. Compliance with datasheet electrical specifications is the customer's responsibility.

■ EQUIPMENT MAINTENANCE

CLEANING (when the product is switched off)

Please use a soft and dry cloth. Do not use any abrasive material. Do not use any cleaning solvent or aggressive chemical product. TPL Vision recommends to use isopropyl alcohol.

■ OPERATING CONDITIONS

-10° to +40°C (14° to +104°F) / 80% of humidity without condensation. No thermal shock (max temperature variation: 10°C (18°F) in 24h). Not for outdoor use.



Brenchley House, School Road
Charing, Kent TN27 0JW
United Kingdom

TPL VISION
IS AN **ISO 9001**
CERTIFIED MANUFACTURER

+44 (0)1738 310 392

contact@tpl-vision.co.uk

www.tpl-vision.com